

Model URP is a full port union supplied with a "PTV" combination manual air vent & Pressure/Temperature test port. Available with multiple combinations of end connection types and sizes.

SPECIFICATIONS

Pressure Ratings: 600 PSI (4140 kPa)
 Temperature Ratings: 250F (120C)
 Body Material: Forged Brass
 End Connections: Brass - Fixed End: SWT, FNPT
 Union End: SWT, FNPT, & MNPT
 Seals: EPDM
 Available Options: Hose end drain valve, port extensions.

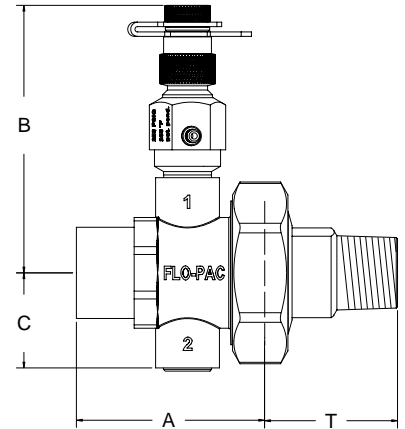

NOMINAL DIMENSIONS & WEIGHTS

Size		A				B	C	*T	Wgt	
in	mm	FNPT	MNPT	SWT			MPT	lbs	kg	
1/2"	15	in	1.99	2.25	1.88	2.77	0.84	1.50	0.79	0.36
		mm	50.47	57.23	47.68	70.25	21.44	38.10		
3/4"	20	in	2.04	2.19	2.12	3.02	1.08	1.56	1.08	0.49
		mm	51.82	55.65	53.90	76.65	27.31	39.70		
1"	25	in	2.15	2.38	2.28	3.02	1.08	1.80	1.10	0.50
		mm	54.56	60.40	57.85	76.65	27.31	45.72		
1-1/4"	32	in	2.39	2.82	2.56	3.39	1.46	1.80	2.22	1.01
		mm	60.63	71.53	65.05	86.18	36.98	45.72		
1-1/2"	40	in	2.39	2.84	2.69	3.39	1.46	1.80	2.33	1.06
		mm	60.63	72.16	68.35	86.18	36.98	45.72		
2"	50	in	2.49	2.96	3.03	3.70	1.76	1.98	3.21	1.46
		mm	63.30	75.26	76.96	94.08	44.75	50.17		

* Please reference the tailpiece data sheet (Form # FP-TP) for other sizes and connections.
Dimensions not for construction purposes unless certified by factory.

STANDARD COMPONENTS



Combination manual air vent and pressure/temperature test port with brass body, dual durometer EPDM core, blowout-proof stem, side discharge vent with 1/8" (4mm) hose barb, threaded brass cap with O-ring seal and neoprene retainer strap. Accepts standard 1/8" (4mm) gauge adapter or thermometer stem. Rated to 250 PSI (1725 kPa) and 250°F (120°)

Please reference Flo-Pac data sheet (Form # FP-ACC) for optional accessories.

ORDER DESIGNATIONS

URP - 075 - S - 050 - M - XX
 Model ————
 Body Size ————
 Conn. Type ————
 Accessories
 Tailpiece Conn. Type
 Tailpiece Conn. Size

Flo-Pac, LLC.
 10545 Guilford Road, Unit 103
 Jessup, Maryland 20794
 www.flo-pacllc.com

Please reference the Ordering Guide (Form # FP-OG) for a complete list of designations